

TB 9-5985-314-35

CHANGE 1

DEPARTMENT OF THE ARMY TECHNICAL BULLETIN

**CALIBRATION PROCEDURE FOR
DIRECTIONAL COUPLERS, VSWR BRIDGES,
COAXIAL CIRCULATORS, POWER SPLITTERS, AND
POWER DIVIDERS (10 MHZ TO 40 GHZ)
(GENERAL)**

Headquarters, Department of the Army, Washington, DC
18 March 2002

Approved for public release; distribution is unlimited.

TB 9-5985-314-35, 24 December 1996, is changed as follows:

1. Remove old pages and insert new pages as indicated below. New or changed material is indicated by a vertical bar in the margin of the page.

Remove pages

1 and 2

C-1 and D-1

Insert pages

1 and 2

C-1 and D-1

2. File this change sheet in front of the publication for reference purposes.

By Order of the Secretary of the Army:

ERIC K. SHINSEKI
General, United States Army
Chief of Staff

OFFICIAL:

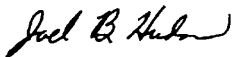

JOEL B. HUDSON
*Administrative Assistant to the
Secretary of the Army*

0202805

Distribution:

To be distributed in accordance with IDN 342085, requirements for calibration procedure TB 9-5985-314-35.

***TB 9-5985-314-35**

DEPARTMENT OF THE ARMY TECHNICAL BULLETIN

CALIBRATION PROCEDURE FOR DIRECTIONAL COUPLERS, VSWR BRIDGES, COAXIAL CIRCULATORS, POWER SPLITTERS, AND POWER DIVIDERS (10 MHZ TO 40 GHZ) (GENERAL)

Headquarters, Department of the Army, Washington, DC
24 December 1996

Approved for public release; distribution is unlimited.

REPORTING OF ERRORS AND RECOMMENDING IMPROVEMENTS

You can help improve this publication. If you find any mistakes or if you know of a way to improve the procedure, please let us know. Mail your letter or DA Form 2028 to: Commander, U. S. Army Aviation and Missile Command, ATTN: AMSAM-MMC-MA-NP, Redstone Arsenal, AL 35898-5230. A reply will be furnished to you. You may also send in your comments electronically to our e-mail address: 2028@redstone.army.mil or FAX 256-842-6546/DSN 788-6546.

		Paragraph	Page
SECTION	I.	IDENTIFICATION AND DESCRIPTION	
		Test instrument identification	1 2
		Forms, records, and reports.....	2 3
		Calibration description.....	3 3
	II.	EQUIPMENT REQUIREMENTS	
		Equipment required.....	4 3
		Accessories required.....	5 3
	III.	CALIBRATION PROCESS FOR DIRECTIONAL COUPLERS	
		Preliminary instructions.....	6 5
		Definitions.....	7 5
		Equipment setup.....	8 6
		Coupling and directivity tests.....	9 8
		Final procedure	10 15

CHANGE 1 1

*This bulletin supersedes TB 9-5985-314-35, dated 3 February 1992.

		Paragraph	Page
	IV. CALIBRATION PROCESS FOR VSWR BRIDGES		
	Preliminary instructions.....	11	15
	Equipment setup	12	15
	Directivity	13	15
	Final procedure	14	17
SECTION	V. CALIBRATION PROCESS FOR COAXIAL CIRCULATORS		
	Preliminary instructions.....	15	17
	Definitions.....	16	17
	Equipment setup	17	18
	Insertion loss and isolation.....	18	18
	Final procedure	19	21
	VI. CALIBRATION PROCEDURE FOR POWER SPLITTERS AND POWER DIVIDERS		
	Preliminary instructions.....	20	22
	Equipment setup	21	22
	Insertion loss and output port tracking.....	22	23
	Final procedure	23	32
APPENDIX	A. DIRECTIONAL COUPLERS TEST INSTRUMENT IDENTIFICATION		A-1
APPENDIX	B. VSWR BRIDGES TEST INSTRUMENT IDENTIFICATION		B-1
APPENDIX	C. THREE PORT CIRCULATOR TEST INSTRUMENT IDENTIFICATION		C-1
APPENDIX	D. POWER SPLITTERS AND POWER DIVIDERS TEST INSTRUMENT IDENTIFICATION		D-1

**SECTION I
IDENTIFICATION AND DESCRIPTION**

1. Test Instrument Identification. This bulletin provides instructions for the calibration of Directional Couplers, VSWR Bridges, Coaxial Circulators, Power Splitters, and Power Dividers (10 MHz to 40 GHz) (General). The manufacturers' manuals were used as the prime data sources in compiling these instructions. The equipment being calibrated will be referred to as the TI (test instrument) throughout this bulletin.

a. Model Variations. Variations among models are described in appendixes A, B, C, and D.

b. Time and Technique. The time required for this calibration is approximately 7 hours, using the microwave technique.

2. Forms, Records, and Reports

a. Forms records, and reports required for calibration personnel at all levels are prescribed by TB 750-25.

b. Adjustments to be reported are designated (R) at the end of the sentence in which they appear. When adjustments are in tables, the (R) follows the designated adjustment. Report only those adjustments made and designated with (R).

3. Calibration Description. TI identification, including manufacturer, model number, parameters, and performance specifications which pertain to this calibration are listed in appendixes A, B, C, and D. TIs other than those listed in appendixes may be certified with the techniques in this procedure if the manufacturers' manuals are available.

**SECTION II
EQUIPMENT REQUIREMENTS**

4. Equipment Required. Table 1 identifies the specific equipment to be used in this calibration procedure. This equipment is issued with Secondary Transfer Calibration Standards Set AN/GSM-287 and Secondary Reference Calibration Standards Set NSN 4931-00-621-7878. Alternate items may be used by the calibrating activity. The items selected must be verified to perform satisfactorily prior to use and must bear evidence of current calibration. The equipment must meet or exceed the minimum use specifications listed in table 1. The accuracies listed in table 1 provide a four-to-one ratio between the standard and TI.

5. Accessories Required. The accessories required for this calibration are common usage accessories, issued as indicated in paragraph 4 above, and are not listed in this calibration procedure. The following peculiar accessory is also required for this calibration: N-short, Hewlett-Packard, Model 11512A (11512A).

Table 1. Minimum Specifications of Equipment Required

Common name	Minimum use specifications	Manufacturer and model (part number)
ATTENUATOR (FIXED)	Range: 30 dB Frequency range: 10 MHz to 18 GHz Accuracy: ±1.0 dB Range: 60 dB Frequency range: 10 MHz to 18 GHz Accuracy: ±1.5 dB	Weinschel, Models 9918-30dB (9918-30dB) and 9918-60dB (9918-60dB)
FREQUENCY EXTENSION KIT NO. 1	Frequency range: 18.0 to 26.5 GHz IF frequency: 700 MHz Combined accuracy with receiver system: ±0.03 dB/10 dB	Weinschel, Model 1611 (1611)
FREQUENCY EXTENSION KIT NO. 2	Frequency range: 26.5 to 40 GHz IF frequency: 1 GHz Combined accuracy with receiver system: ±0.03 dB/10 dB	Weinschel, Model 1612 (1612)

See footnotes at end of table.

TB 9-5985-314-35

Table 1. Minimum Specifications of Equipment Required - Continued

Common name	Minimum use specifications	Manufacturer and model (part number)
MISMATCH SETS	Frequency range: 0.01 to 18 GHz VSWR: ¹ 1.05 \pm .00, \pm .05 (0.01 to 4 GHz) \pm .05 (4 to 18 GHz) 1.2 \pm .10 1.50 \pm .17 2.00 \pm .22 Frequency range: 18 to 26.5 GHz 1.105 \pm 0.0035 ² 1.5 \pm 0.0073 ² Frequency range: 26.5 to 40 GHz 1.105 \pm 0.004 ² 1.5 \pm 0.007 ²	Mismatch Set 7916980 (7916980) Mismatch Set 7913200-3-2 (7913200-3-2), 7913200-3-5 (7913200-3-5) Mismatch Set 7913200-4-2 (7913200-4-2), 7913200-4-5 (7913200-4-5)
POWER METER	Frequency range: 10 MHz to 26.5 GHz Power range: -7 to +3 dBm Accuracy: \pm 0.7 dB	Hewlett-Packard, Model E12-432A (MIS-30525) w/thermistor mount, Hewlett-Packard, Model 8478B(8478B)
POWER SPLITTER NO. 1	Frequency range: 10 MHz to 18 GHz Insertion loss: -6 dB -0.2 +1.5 dB Output tracking between ports: 10 MHz to 2 GHz: \pm 0.15 dB 2 to 8 GHz: \pm 0.2 dB 8 to 18 GHz: \pm 0.25 dB	Weinschel, Model 1870A (7916839)
POWER SPLITTER NO. 2	Frequency range: 10 MHz to 40 GHz Output tracking between ports: 10 MHz to 18 GHz: \pm 0.3 dB 18 to 40 GHz: \pm 0.6 dB	Wiltron, Model K241 () (K241 ())
PROGRAMMABLE SWEEP GENERATOR	Frequency range: 10 MHz to 40 GHz Power output: 0 to +6 dBm	Wiltron, Model 6669M (6669M)
RECEIVER SYSTEM	Frequency range: 10 MHz to 18 GHz Attenuation range: 0.00 to 48 dB Accuracy: \pm 0.02 dB/10 dB	Weinschel, Model VM4A (VM4A)
SIGNAL GENERATOR	Frequency range: 8650 to 13,333 MHz Power output: +3 to +8 dBm Accuracy: \pm 2 dB	(SG-1219/U)
SLIDING TERMINATION	Impedance: 50 Ω Frequency range: 1.8 to 18 GHz VSWR: 1.05 Impedance: 50 Ω Frequency range: 18 to 26.5 GHz VSWR: Impedance: 50 Ω Frequency range: 26.5 to 40 GHz VSWR:	Hewlett-Packard, Model 905A (905A) Systron, Model DBE456-1 (DBE456-1) Systron, Model DBD456-1 (DBD456-1)

See footnotes at end of table.

Table 1. Minimum Specifications of Equipment Required

Common name	Minimum use specifications	Manufacturer and model (part number)
TERMINATION ³	Frequency range: 8.2 to 12.4 GHz VSWR: 1.015 (max) Impedance: 50Ω	Hewlett-Packard, Model X910B (X910B)
	Frequency range: 12.4 to 18 GHz VSWR: 1.02 (max) Impedance: 50Ω	Hewlett-Packard, Model P910A (P910A)
	Frequency range: 18 to 26.5 GHz VSWR: ¹ Impedance: 50Ω	Maury Microwave, Model U301 (U301)
	Frequency range: 26.5 to 40 GHz VSWR: ¹ Impedance: 50Ω	Maury Microwave, Model U301 (U301)
	Frequency range: DC to 18 GHz VSWR: ¹	Maury Microwave, Model 2334-001-1 (2334-001-1)

¹As charted on calibration report provided by Primary Lab (for secondary reference only).

²Reflection coefficient.

³Select as required: Two may be required.

SECTION III CALIBRATION PROCESS FOR DIRECTIONAL COUPLERS

6. Preliminary Instructions

a. The instructions outlined in paragraphs **6** through **8** are preparatory to the calibration process. Personnel should become familiar with the entire bulletin before beginning the calibration.

b. Items of equipment used in this procedure are referenced within the text by common name as listed in table 1.

c. Unless otherwise specified, verify the result of each test and, whenever the test requirement is not met, take corrective action before continuing with the calibration. Omit steps for parameters listed in appendix A with the statement N/A.

7. Definitions. Explanation of terms peculiar to directional couplers are listed in **a** through **d** below to ensure accurate interpretation of the measurement techniques used in this procedure.

a. Nominal Coupling. The nominal loss between the primary input port and the auxiliary side arm port, with the output port terminated, is called coupling. Normally coupling is expressed in dB.

TB 9-5985-314-35

b. Coupling Variation. The maximum average deviation from the coupling value resulting from manufacturing process, is called coupling variation and is normally expressed in dB.

c. Frequency Sensitivity. The allowable deviation from the average coupling value (coupling variation), resulting from the frequency characteristics of a directional coupler, is called frequency sensitivity and is normally expressed in dB.

d. Directivity. The difference between the coupling value (in dB) and the insertion loss (isolation) (in dB) measured between the output port and side arm port (reverse direction) with the input port terminated is called directivity and is expressed in dB.

8. Equipment Setup

a. Use appendix A to determine TI parameters as listed in (1) through (5) below:

- (1) Frequency range.
- (2) Coupling value.
- (3) Coupling variation.
- (4) Frequency sensitivity.
- (5) Directivity.

b. Select appropriate equipment setup for TI frequency range from figures as listed in (1) through (3) below:

- (1) 10 MHz to 18 GHz, figure 1.
- (2) 18 to 26.5 GHz, figure 2.
- (3) 26.5 to 40 GHz, figure 3.

c. Determine and record a minimum of 10 evenly spaced test frequencies over the TI entire frequency range.

d. Connect equipment as shown in figure 1, 2, or 3 and allow 1 hour for equipment warmup for figure 1 (3 hours for figures 2 and 3).

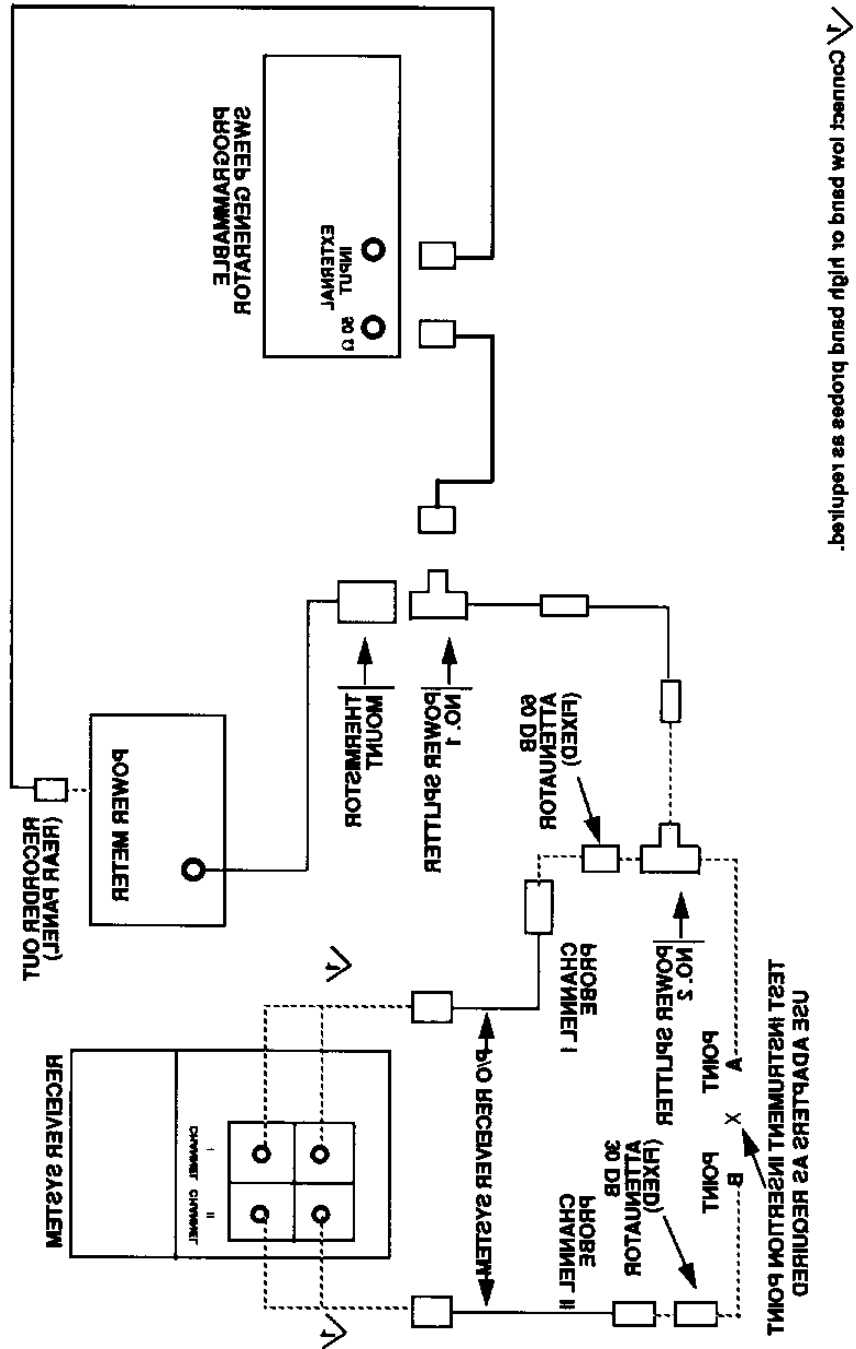

Figure 1. Equipment setup (10 MHz to 18 GHz)

9. Coupling and Directivity Tests

a. Performance Check

NOTE

Perform (1) through (8) below for TI test frequencies from 10 MHz to 18 GHz.

Perform (9) through (19) below for TI test frequencies from 18 to 26.5 GHz.

Perform (20) through (32) below for TI test frequencies from 26.5 to 40 GHz.

(1) Adjust programmable sweep generator frequency controls to test frequency recorded in **8c** above and external level **RF LEVEL** output controls for a power meter indication of 0 dBm.

(2) Connect POINT A to POINT B (fig. 1). Press receiver system frequency to test frequency recorded in **8c** above and establish a 0.00 dB reference.

NOTE

Use 15 percent search on receiver system.

(3) Connect TI into figure 1 equipment setup as listed in (a) through (d) below:

(a) **INPUT PORT** to POINT A.

(b) **SIDEARM PORT** to POINT B.

(c) **OUTPUT PORT** to 50Ω termination.

(d) **AUX (TEST) SIDE ARM PORT** (if any) to 50Ω termination.

NOTE

Ensure receiver is in measurement mode.

(4) Record receiver system indication. Receiver system indication will be within the nominal coupling value $\pm(\text{coupling variation}) + (\pm\text{frequency sensitivity})$ tolerances listed for TI in appendix A.

(5) Establish a 0.00 reference on receiver system.

(6) Connect TI into figure 1 equipment setup as listed in (a) through (d) below:

- (a) **OUTPUT PORT** to POINT A.
- (b) **SIDEARM PORT** to POINT B.
- (c) **INPUT PORT** to 50Ω termination.
- (d) **AUX (TEST) SIDEARM PORT** (if any) to 50Ω termination.

NOTE

Ensure receiver system is in measurement mode.

(7) Record receiver system indication. Receiver system indication will be greater than or equal to the value listed in TI directivity column, appendix A.

(8) Repeat technique of (1) through (7) above for remaining test frequencies recorded in **8c** above.

NOTE

Perform (9) through (19) below for TI test frequencies from 18 to 26.5 GHz.

NOTE

Ensure equipment is connected as shown in figure 2 and has completed the 3 hour warmup before proceeding to (9) below.

(9) Adjust programmable sweep generator frequency controls to test frequency recorded in **8c** above and **RF LEVEL** output controls for +3 dBm.

(10) Determine signal generator frequency (LO) required for the desired measurement by calculating the following equation: $LO = (RF-IF)/2$ where:

RF = test frequency recorded in **8c** above IF = intermediate frequency at which receiver system is to perform measurement (0.700 GHz).

EXAMPLE:

Let IF = 0.700 GHz

RF = 18 GHz (test frequency **8c** above)

LO = signal generator frequency

$LO = (RF-IF)/2$

$LO = (18 \text{ GHz}-0.700 \text{ GHz})/2$ $LO = 17.3 \text{ GHz}/2$

LO = 8.65 GHz

Signal generator frequency for this measurement would be 8.65 GHz.

NOTE

Use receiver system in **15% SEARCH MODE**.

(11) Press receiver system frequency to 0.700 GHz.

(12) Adjust signal generator frequency to value determined in (10) above and **RF OUTPUT** to +8 dBm.

(13) Connect POINT A to POINT B (fig. 2) and establish a 0.00 dBm reference on receiver system.

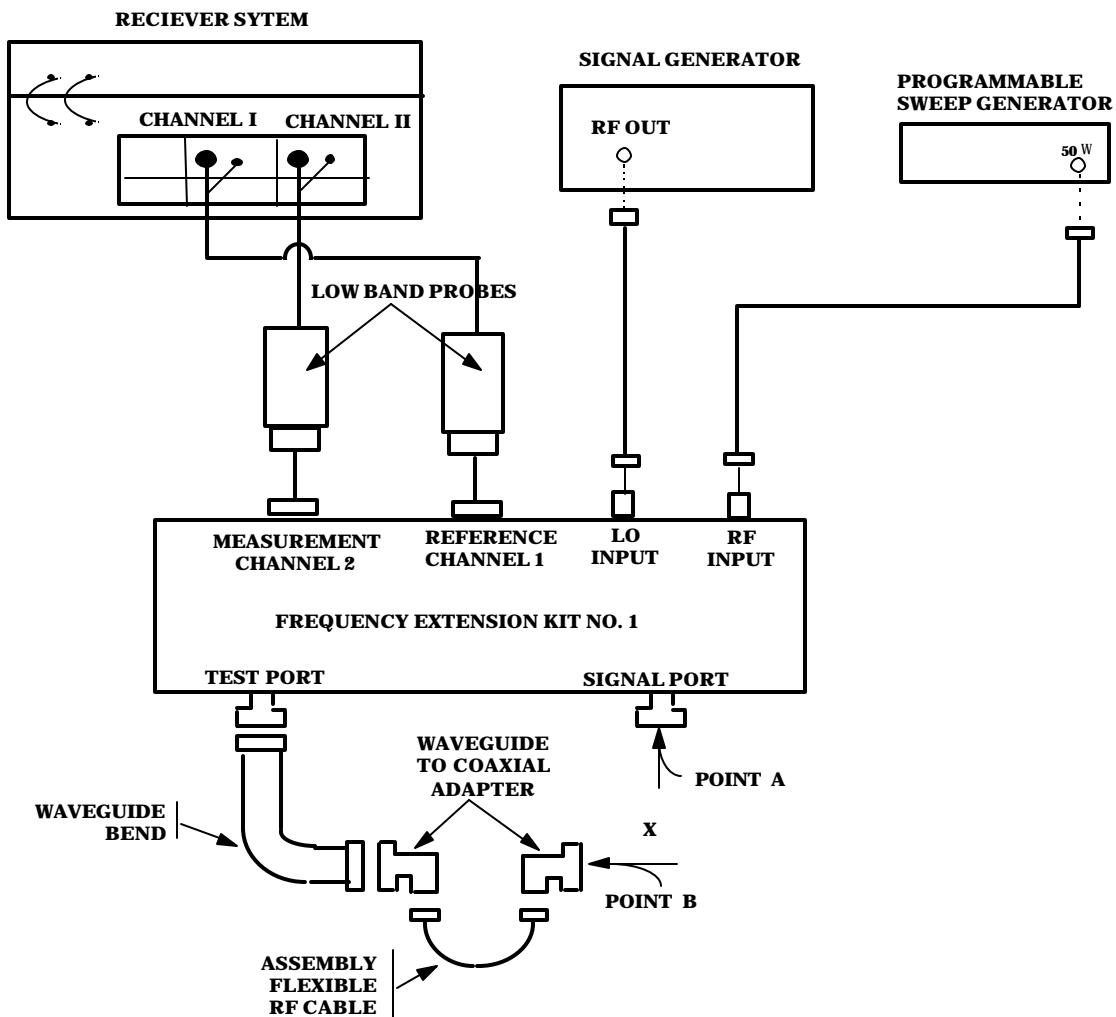

Figure 2. Equipment setup (18 to 26.5 GHz)

- (14) Connect TI into figure 2 equipment setup as listed in (a) through (d) below:
- (a) **INPUT PORT** to POINT A.
 - (b) **SIDEARM PORT** to POINT B.
 - (c) **OUTPUT PORT** to 50Ω termination.
 - (d) **AUX (TEST) SIDEARM PORT** (if any) to 50Ω termination.

NOTE

Ensure receiver system is in measurement mode.

(15) Record receiver system indication. Receiver system indication will be within the nominal coupling $\pm(\text{coupling variation}) + (\pm\text{frequency sensitivity})$ tolerances listed for TI in appendix A.

- (16) Establish a 0.00 dB reference on receiver system.
- (17) Connect TI into figure 2 equipment setup as listed in (a) through (d) below:
- (a) **OUTPUT PORT** to POINT A.
 - (b) **SIDEARM PORT** to POINT B.
 - (c) **INPUT PORT** to 50Ω termination.
 - (d) **AUX (TEST) SIDEARM PORT** (if any) to 50Ω termination.

NOTE

Ensure receiver system is in measurement mode.

(18) Record receiver system indication. Receiver system indication will be greater than or equal to the value listed for TI in directivity column, appendix A.

(19) Repeat technique of (9) through (18) above for remaining test frequencies recorded in **8c** above.

NOTE

Perform (20) through (32) below for TI with frequency range from 26.5 to 40 GHz.

(20) Determine signal generator (RF) frequency required for the desired measurement by calculating the following equation: $RF = \text{test frequency in } \mathbf{8c} \text{ above}/3$.

TB 9-5985-314-35

EXAMPLE A:

If test frequency recorded in **8c** above is 27 GHz,

$$RF = 27 \text{ GHz}/3$$

$$RF = 9 \text{ GHz}$$

Signal generator frequency would be adjusted to 9 GHz.

(21) Adjust signal generator frequency controls to value determined in (20) above and adjust RF output to +3 dBm.

(22) Determine programmable sweep generator frequency (LO) required for the desired measurement by calculating the following equation: $LO = ((3 \times RF) - IF)/2$.

EXAMPLE B:

Where: RF = signal generator frequency determined in 20 above.

IF = operating frequency of receiver system (1 GHz)

LO = Programmable sweep generator frequency

$$LO = ((3 \times RF) - IF)/2$$

$$LO = ((3 \times 9 \text{ GHz}) - 1 \text{ GHz})/2$$

$$LO = 26 \text{ GHz}/2$$

$$LO = 13 \text{ GHz}$$

Programmable sweep generator frequency would be adjusted to 13 GHz.

(23) Adjust programmable sweep generator controls to frequency determined in (22) above and adjust **RF LEVEL** output to 0 dBm.

(24) Connect equipment as shown in figure 3.

NOTE

Ensure equipment is connected as shown in figure 3 and has completed the 3-hour warmup before proceeding to (25) below.

NOTE

Use **15% SEARCH MODE** on receiver system.

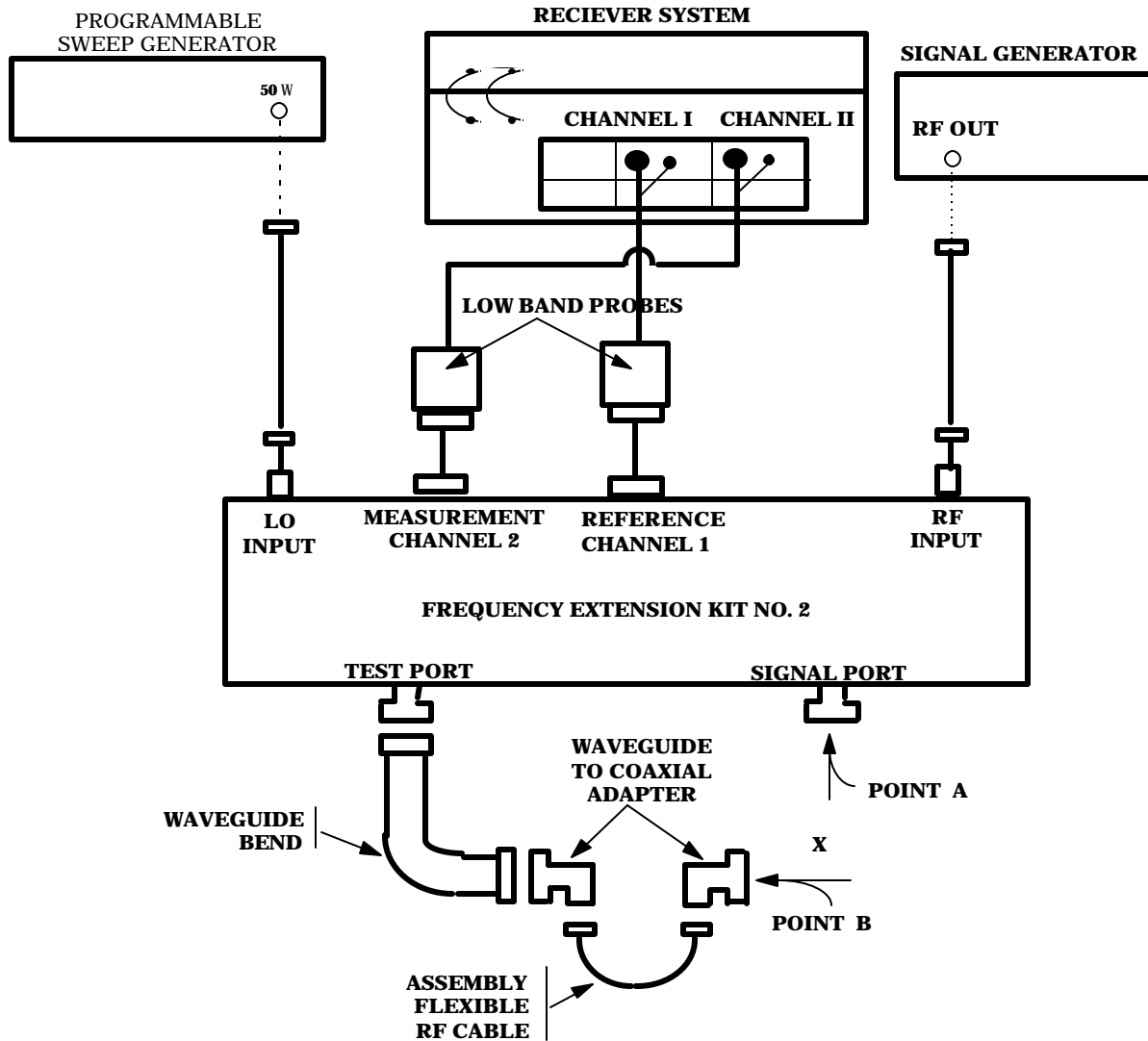

Figure 3. Equipment setup (26.5 to 40 GHz)

(25) Press receiver frequency to 1 GHz.

(26) Connect POINT A to POINT B (fig. 3) and establish a 0.00 dB reference on receiver system.

(27) Connect TI into figure 3 equipment setup as listed in (a) through (d) below:

(a) **INPUT PORT** to POINT A.

(b) **SIDEARM PORT** to POINT B.

TB 9-5985-314-35

- (c) **OUTPUT PORT** to 50Ω termination.
- (d) **AUX (TEST) SIDEARM PORT** (if any) to 50Ω termination.

NOTE

Ensure receiver system is in measurement mode.

(28) Record receiver system indication. Receiver system indication will be within the Nominal Coupling \pm (Coupling Variation) \pm (Frequency Sensitivity) tolerances listed for TI in appendix A.

(29) Establish a 0.00 dB reference on receiver system.

(30) Connect TI as shown in figure 3 equipment setup as listed in (a) through (d) below:

- (a) **OUTPUT PORT** to POINT A.
- (b) **SIDEARM PORT** to POINT B.
- (c) **INPUT PORT** to 50Ω termination.
- (d) **AUX (TEST) SIDEARM PORT** (if any) to 50Ω termination.

NOTE

Ensure receiver system is in measurement mode.

(31) Record receiver system indication. Receiver system indication will be greater than or equal to the value listed for TI in directivity column, appendix A.

(32) Repeat technique of (20) through (31) above for remaining test frequencies recorded in **8c** above.

b. Adjustment. No adjustments can be made; however, a correction chart may be prepared listing actual coupling and directivity values at test frequencies.

NOTE

When determining directivity, in- or out-of-tolerance condition, all of the below must be considered:

1. Termination mismatch errors can cause measured directivity to appear slightly lower than normal.
2. A 10 percent variation in directivity is acceptable for most directional couplers used in direct support of field activities in the U. S. Army.
3. A directional coupler may be out of tolerance at a specific frequency and still be useable over the rest of its range.

10. Final Procedure

- a. Deenergize and disconnect all equipment.
- b. Annotate and affix DA label/form in accordance with TB 750-25.

**SECTION IV
CALIBRATION PROCESS FOR VSWR BRIDGES**

11. Preliminary Instructions

a. The instructions outlined in paragraphs **11** and **12** are preparatory to the calibration process. Personnel should become familiar with the entire bulletin before beginning the calibration.

b. Items of equipment used in this procedure are referenced within the text by common name as listed in table 1.

c. Unless otherwise specified, verify the result of each test and, whenever the test requirement is not met, take corrective action before continuing with the calibration.

12. Equipment Setup

- a. Use appendix B to determine TI parameters for directivity.

NOTE

Clean all connectors with alcohol before proceeding with **b** below.

- b. Connect equipment as shown in figure 1 and allow 1 hour for equipment warmup.

NOTE

Do not connect TI into equipment setup at this time.

c. Determine and record a minimum of 10 evenly spaced test frequencies over the TI entire frequency range.

13. Directivity

a. Performance Check

(1) Adjust programmable sweep generator frequency controls to test frequency recorded in **12c** above and external level **RF LEVEL** output controls for a power meter indication of 0 dBm.

TB 9-5985-314-35

(2) Connect TI as shown in figure 1 equipment setup. Press receiver system frequency to test frequency recorded in **12c** above.

NOTE

Use **15% SEARCH MODE** on receiver system.

(3) Connect N-short to TI **DEVICE UNDER TEST** port and establish a 0.0 dB reference on receiver system.

(4) Remove N-short from TI and connect sliding termination to TI **DEVICE UNDER TEST** port.

NOTE

Ensure receiver is in measurement mode.

NOTE

Use fixed termination (model 2334-001-1) for Wiltron, Model 60NF50. Disregard minimum/maximum indications in (5) and (6) below. Record receiver system indication and proceed to (7) below.

(5) Adjust sliding termination for a minimum and then an adjacent maximum receiver system indication. Record receiver minimum and maximum indications.

(6) Determine TI directivity by calculating the below listed formula.

$$D \text{ average} = (\text{min} + \text{max})/2$$

Where: D average is directivity

Min is receiver system minimum indication

Max is receiver system maximum indication

(7) Directivity (D average or receiver system indication recorded in note above) will be greater than or equal to the value listed for TI in appendix B.

(8) Remove sliding termination (termination) from TI **DEVICE UNDER TEST** port.

(9) Connect mismatches as listed in table 2 to TI **DEVICE UNDER TEST** port. Return loss in dB indication displayed on receiver system will be with the limits specified in table 2 (for secondary reference as stated in test report plus or minus specifications of SWR bridges).

(10) Repeat technique of (1) through (9) above for remaining test frequencies recorded in **12c** above.

b. Adjustments. No adjustments can be made.

Table 2. Return Loss Measurements

Mismatch ¹		Receiver system indications (return loss dB) ²								
Model	Manufacturer	VSWR value	Dc to 4 GHz		4 to 8 GHz		8 to 12.4 GHz		12.4 to 18 GHz	
			Min	Max	Min	Max	Min	Max	Min	Max
(2334-001-1)	Premier Microwave	1.05 +.00 -.05 ±.05	32.26	40.00 ³ or greater	26.44	---	---	---	---	40.00 ³ or greater
(2334-001-2)	Premier Microwave	1.20 ±.10	17.69	---	---	---	---	---	---	26.44
(2334-001-3)	Premier Microwave	1.50 ±.17	12.01	---	---	---	---	---	---	16.98
(2334-001-4)	Premier Microwave	2.00 +.22	8.43	---	---	---	---	---	---	11.04

¹With test report provided by Primary Lab for Secondary Reference.

²Receiver system indications (return loss dB) include .02/10 dB.

³Standards limitations.

14. Final Procedure

- a. Deenergize and disconnect all equipment and reinstall protective cover on TI.
- b. Annotate and affix DA label/form in accordance with TB 750-25.

**SECTION V
CALIBRATION PROCESS FOR
COAXIAL CIRCULATORS**

15. Preliminary Instructions

a. The instructions outlined in paragraphs **15** through **17** are preparatory to the calibration process. Personnel should become familiar with the entire bulletin before beginning the calibration.

b. Items of equipment used in this procedure are referenced within the text by common name.

c. Unless otherwise specified, verify the results of each test and, whenever the test requirement is not met, take corrective action before continuing with the calibration.

TB 9-5985-314-35

16. Definitions. Explanation of terms peculiar to coaxial circulators is listed in **a** through **d** below to ensure accurate interpretation of the measurement techniques used in this procedure.

a. Isolation. Electrical or acoustical separation between two locations is normally expressed in dB (a measurement against energy flow).

b. Insertion loss. The difference between the power received at the load before and after the insertion of apparatus at some point in the line and normally expressed in dB (a measurement made with forward energy flow).

c. Forward energy flow. The direction in which energy is allowed to pass through a device with very little RF loss.

d. Reverse energy flow. The direction in which RF energy is opposed in passing through the device.

17. Equipment Setup

NOTE

Use appendix C to determine TI parameters for isolation and insertion loss.

NOTE

Clean all connectors with alcohol.

Connect equipment as shown in figure 1, and allow 1 hour for equipment warmup.

NOTE

Do not connect TI into equipment setup at this time.

18. Insertion Loss and Isolation

a. Performance Check

(1) Adjust programmable sweep generator frequency controls to 0.960 GHz and external level **RF LEVEL** output controls for a 0 dBm indication on power meter.

NOTE

Ensure 0 dBm indication on power meter is maintained throughout the measurements performed below.

NOTE

Use **15% SEARCH MODE** on receiver system.

- (2) Connect POINT A to POINT B (fig. 1) and establish a reference 0.00 dB on receiver system at 0.960 GHz.
- (3) Connect TI into figure 1 equipment setup as listed in (a) through (c) below:
 - (a) **INPUT PORT** to POINT A.
 - (b) **OUTPUT PORT** to POINT B.
 - (c) **SIDE PORT** to 50Ω termination.
- (4) Receiver system indication will be 0.5 dB or less.
- (5) Adjust programmable sweep generator and receiver system frequency controls to frequency settings listed in table 3. Receiver system indication will be 0.5 dB or less.

NOTE

Ensure 0 dBm power meter indication is maintained for (4) and (5) above.

Table 3. Coaxial Circulator Frequencies

GHz
0.960
1.000
1.030
1.060
1.090
1.100

- (6) Repeat (1) and (2) above.
- (7) Connect TI into figure 1 equipment setup as listed in (a) through (c) below:
 - (a) **OUTPUT PORT** to POINT A.
 - (b) **INPUT PORT** to POINT B.
 - (c) **SIDE PORT** to 50Ω termination.
- (8) Receiver system indication will be 20 dB or greater.
- (9) Adjust programmable sweep generator and receiver system frequency controls to frequency settings listed in table 3. Receiver system indication will be 20 dB or greater.

NOTE

Ensure 0 dBm indication is maintained on power meter for (8) and (9) above.

(10) Repeat (1) and (2) above.

(11) Connect TI into figure 1 equipment setup as listed in (a) through (c) below:

(a) **OUTPUT PORT** to POINT A.

(b) **SIDE PORT** to POINT B.

(c) **INPUT PORT** to 50Ω termination.

(12) Receiver system indication will be 0.5 dB or less.

(13) Adjust programmable sweep generator and receiver system frequency controls to frequency settings listed in table 3. Receiver system indication will be 0.5 dB or less.

NOTE

Ensure 0 dBm indication is maintained on power meter in (12) and (13) above.

(14) Repeat (1) and (2) above.

(15) Connect TI into figure 1 equipment setup as listed in (a) through (c) below:

(a) **SIDE PORT** to POINT A.

(b) **OUTPUT PORT** to POINT B.

(c) **INPUT PORT** to 50Ω termination.

(16) Receiver system will indicate 20 dB or greater.

(17) Adjust programmable sweep generator and receiver system frequency controls to frequency settings listed in table 3. Receiver system indication will be 20 dB or greater.

NOTE

Ensure 0 dBm indication is maintained on power meter in (16) and (17) above.

- (18) Repeat (1) and (2) above.
- (19) Connect TI into figure 1 equipment setup as listed in (a) through (c) below:
 - (a) **SIDE PORT** to POINT A.
 - (b) **INPUT PORT** to POINT B.
 - (c) **OUTPUT PORT** to 50Ω termination.
- (20) Receiver system indication will be 0.5 dB or less.

NOTE

Ensure 0 dBm indication is maintained on power meter in (20) and (21) above.

(21) Adjust programmable sweep generator and receiver system frequency controls to frequency settings listed in table 3. Receiver system indication will be 0.5 dB or less.

(22) Repeat (1) and (2) above.

(23) Connect TI as shown in figure 1, equipment setup as listed in (a) through (c) below:

- (a) **INPUT PORT** to POINT A.
- (b) **SIDE PORT** to POINT B.
- (c) **OUTPUT PORT** to 50Ω termination.

(24) Receiver system indication will be 20 dB or greater.

(25) Adjust programmable sweep generator and receiver system frequency controls to frequency settings listed in table 3. Receiver system indication will be 20 dB or greater.

NOTE

Ensure 0 dBm indication is maintained on power meter in (24) and (25) above.

b. Adjustments. No adjustments can be made.

19. Final Procedure

- a.** Deenergize and disconnect all equipment and reinstall protective cover on TI.
- b.** Annotate and affix DA label/form in accordance with TB 750-25.

**SECTION VI
CALIBRATION PROCESS FOR
POWER SPLITTERS AND POWER DIVIDERS**

20. Preliminary Instructions

a. The instructions outlined in paragraphs **20** and **21** are preparatory to the calibration process. Personnel should become familiar with the entire bulletin before beginning the calibration.

b. Items of equipment used in this procedure are referenced within the text by common name.

c. Unless otherwise specified, verify the results of each test and, whenever the test requirement is not met, take corrective action before continuing with the calibration.

21. Equipment Setup

a. Use appendix D to determine TI parameters for insertion loss and output tracking.

NOTE

Clean all connectors with alcohol before proceeding with **b** below.

b. Connect equipment as shown in figure 4, for TIs with frequency range from 10 MHz to 18 GHz. Allow 1 hour for equipment warmup.

NOTE

Equipment shown in figure 5 is for TIs with frequency range from 18 to 26.5 GHz. Allow 3 hours for equipment warmup.

NOTE

Equipment shown in figure 6 is for TIs with frequency range from 26.5 to 40 GHz. Allow 3 hours for equipment warmup.

NOTE

Do not connect TI into equipment setup at this time.

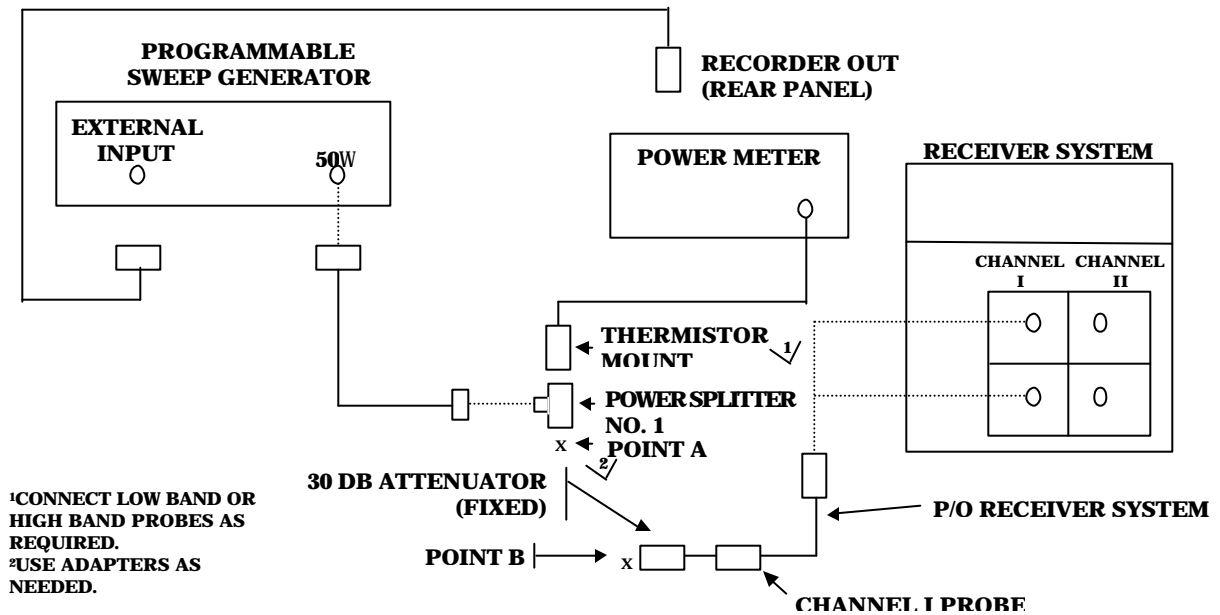

Figure 4. Power splitter measurement (10 MHz to 18 GHz) - equipment setup.

22. Insertion Loss and Output Port Tracking

a. Performance Check

NOTE

Perform 1 through 4 below for TIs with frequency range listed in appendix D specifications.

1. 10 MHz to 1.9 GHz perform (1) through (11).
2. 2 to 18 GHz perform (12) through (22).
3. 18 to 26.5 GHz perform (23) through (35).
4. 26.5 to 40 GHz perform (36) through (48).

(1) Connect equipment as shown in figure 4.

(2) Adjust programmable sweep generator frequency controls to 10 MHz and external level **RF LEVEL** output controls for a 0 dBm indication on power meter.

NOTE

Ensure 0 dBm indication on power meter is maintained throughout the measurements.

NOTE

Use **15% SEARCH MODE** on receiver system.

(3) Connect POINT A to POINT B (fig. 4) and establish a 0.00 dB reference on receiver system at 10 MHz.

(4) Connect TI into 4 equipment setup as listed in (a) through (c) below:

- (a) **INPUT PORT 1** to POINT A.
- (b) **OUTPUT PORT 2** to POINT B.
- (c) **OUTPUT PORT 3** to coaxial reflection standard.

(5) Record receiver system indication in table 4 insertion loss for output port 2 column.

(6) Adjust receiver system and programmable sweep generator frequency controls to remaining test frequency settings listed in table 4. Record receiver system indication in insertion loss for output port 2 column in table 4. Insertion loss will be equal to or less than the limits listed in appendix D.

NOTE

Ensure 0 dBm indication is maintained on power meter for (5) and (6) above.

Table 4. Insertion Loss - Output Port Tracking (10 MHz to 1.9 GHz)

Test frequency (GHz)	Receiver system indication insertion loss		OUTPUT PORT TRACKING (dB)
	OUTPUT PORT 2 (dB)	OUTPUT PORT 3 (dB)	
0.010			
0.050			
0.100			
0.280			
0.460			
0.640			
0.820			
1.000			
1.180			
1.360			
1.540			
1.720			
1.900			

- (7) Disconnect TI from equipment setup and repeat (2) and (3) above.
- (8) Connect TI into figure 4 equipment setup as listed in (a) through (c) below:
 - (a) **INPUT PORT 1** to POINT A.
 - (b) **OUTPUT PORT 3** to POINT B.
 - (c) **OUTPUT PORT 2** to coaxial reflection standard.
- (9) Record receiver system indication in table 4 insertion loss for output port 3 column.
- (10) Press receiver system and programmable sweep generator frequency controls to remaining frequency settings listed in table 4. Record receiver system indication in insertion loss for output port 3 column in table 4. Insertion loss will be equal to dBm or less than the limits listed in appendix D.
- (11) Algebraically calculate the difference between the values recorded for **OUTPUT PORT 2** and **OUTPUT PORT 3** in table 4. Record results in output port tracking column in table 4. Output tracking will be within the limits specified in appendix D.

NOTE

Ensure 0 dBm indication is maintained on power meter for (10) and (11) above.

NOTE

Perform (12) through (22) below for TI with frequency range from 2 to 18 GHz.

- (12) Connect equipment as shown in figure 4.
- (13) Adjust programmable sweep generator frequency to 2.000 GHz and external level **RF LEVEL** output controls for a 0 indication on power meter controls.

NOTE

Use **15% SEARCH MODE** on receiver system.

- (14) Connect POINT A to POINT B (fig. 4) and establish a 0.00 dB reference on receiver system at 2.000 GHz.
- (15) Connect TI into figure 4 equipment setup as listed in (a) through (c) below:
 - (a) **INPUT PORT 1** to POINT A.
 - (b) **OUTPUT PORT 2** to POINT B.
 - (c) **OUTPUT PORT 3** to coaxial reflection standard..

TB 9-5985-314-35

(16) Record receiver system indication in output port 2 column of table 5.

(17) Adjust programmable sweep generator and receiver system frequency controls to measure and record insertion loss for **OUTPUT PORT 2** for remaining frequencies listed in table 5. Insertion loss will be equal to or less than the limits listed in appendix D.

Table 5. Insertion Loss - Output Port Tracking (2 to 18 GHz)

Test Frequency (GHz)	Receiver system indication Insertion loss		OUTPUT PORT TRACKING (dB)
	OUTPUT PORT 2 (dB)	OUTPUT PORT 3 (dB)	
2.000			
2.500			
3.000			
3.500			
4.000			
4.500			
5.000			
5.500			
6.000			
6.500			
7.000			
7.500			
8.000			
8.500			
9.000			
9.500			
10.000			
10.500			
11.000			
11.500			
12.000			
12.500			
13.000			
13.500			
14.000			
14.500			
15.000			
15.500			
16.000			
16.500			
17.000			
17.500			
18.000			

(18) Disconnect TI from equipment setup and repeat (13) and (14) above.

(19) Connect TI into figure 4 equipment setup as listed in (a) through (c) below:

- (a) **INPUT PORT 1** to POINT A.
- (b) **OUTPUT PORT 3** to POINT B.
- (c) **OUTPUT PORT 2** to coaxial reflection standard.

(20) Record receiver system indication in output port 3 column of table 5.

(21) Adjust programmable sweep generator and receiver system frequency controls to measure and record insertion loss for output port 3 for remaining frequencies listed in table 5. Insertion loss will be equal to or less than the limits listed in appendix D.

(22) Algebraically calculate the difference between the values recorded for output port 2 and output port 3 columns of table 5. Record difference in output port tracking column in table 5. Output tracking will be within the limits specified in appendix D.

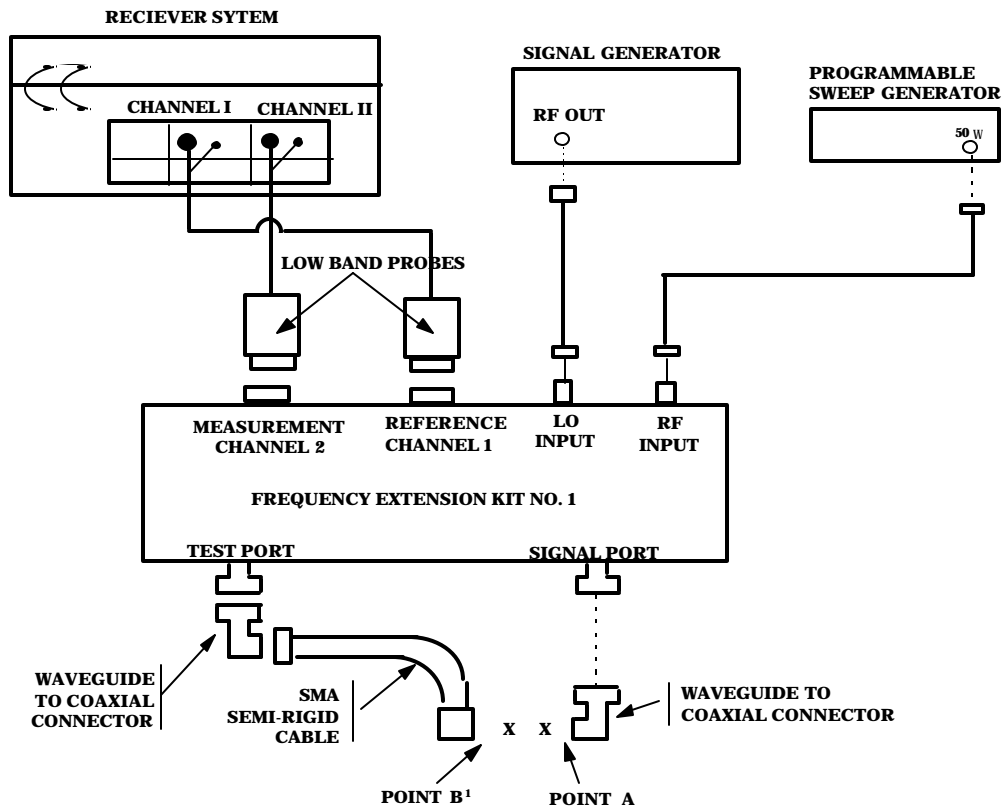

Figure 5. Power splitter measurement (18 to 26.5 GHz) - equipment setup

TB 9-5985-314-35

NOTE

Perform (23) through (35) below for TI with frequency range from 18 to 26.5 GHz.

(23) Connect equipment as shown in figure 5.

(24) Adjust programmable sweep generator frequency controls to 18000 MHz and **RF LEVEL** output controls to +3 dBm.

(25) Press signal generator frequency to 8650 MHz and adjust **RF OUTPUT** controls to +8 dBm.

NOTE

Use **15% SEARCH MODE** on receiver system.

(26) Press receiver system frequency to 0.700 GHz.

(27) Connect POINT A to POINT B (fig. 5) and establish a 0.00 dB reference on receiver system.

(28) Connect TI into figure 5 equipment setup as listed in (a) through (c) below:

- (a) **INPUT PORT 1** to POINT A.
- (b) **OUTPUT PORT 2** to POINT B.
- (c) **OUTPUT PORT 3** to 50Ω termination.

(29) Record receiver system indication in output port 2 column of table 6.

(30) Adjust programmable sweep generator and signal generator frequency controls to remaining frequency settings listed in table 6. Measure and record insertion loss for output port 2 column in table 6. Insertion loss will be approximately equal to value listed in appendix D.

Table 6. Insertion Loss - Output Port Tracking (18 to 26.5 GHz)

Programmable sweep generator (GHz)	Signal generator (MHz)	Receiver system indication insertion loss		OUTPUT PORT TRACKING (dB)
		OUTPUT PORT 2 (dB)	OUTPUT PORT 3 (dB)	
18.000	8650			
18.500	8900			

Table 6. Insertion Loss - Output Port Tracking (18 to 26.5 GHz) - Continued

Programmable sweep generator (GHz)	Signal generator (MHz)	Receiver system indication insertion loss		OUTPUT PORT TRACKING (dB)
		OUTPUT PORT 2 (dB)	OUTPUT PORT 3 (dB)	
19.000	9150			
19.500	9400			
20.000	9650			
20.500	9900			
21.000	10,150			
21.500	10,400			
22.000	10,650			
22.500	10,900			
23.000	11,150			
23.500	11,400			
24.000	11,650			
24.500	11,900			
25.000	12,150			
25.500	12,400			
26.000	12,650			
26.500	12,900			

(31) Repeat (24), (25), and (27) above.

(32) Connect TI into figure 5 equipment setup as listed in (a) through (c) below:

- (a) **INPUT PORT 1** to POINT A.
- (b) **OUTPUT PORT 3** to POINT B.
- (c) **OUTPUT PORT 2** to 50Ω termination.

(33) Record receiver system indication in output port 3 column of table 6.

(34) Adjust programmable sweep generator and signal generator frequency controls to remaining settings listed in table 6. Measure and record insertion loss for **OUTPUT PORT 3** in table 6. Insertion loss will be approximately equal to value listed in appendix D.

(35) Algebraically calculate the difference between the values recorded in table 6 for **OUTPUT PORT 2** and **OUTPUT PORT 3**. Record difference in output port tracking column of table 6. Output tracking will be within the limits specified listed in appendix D.

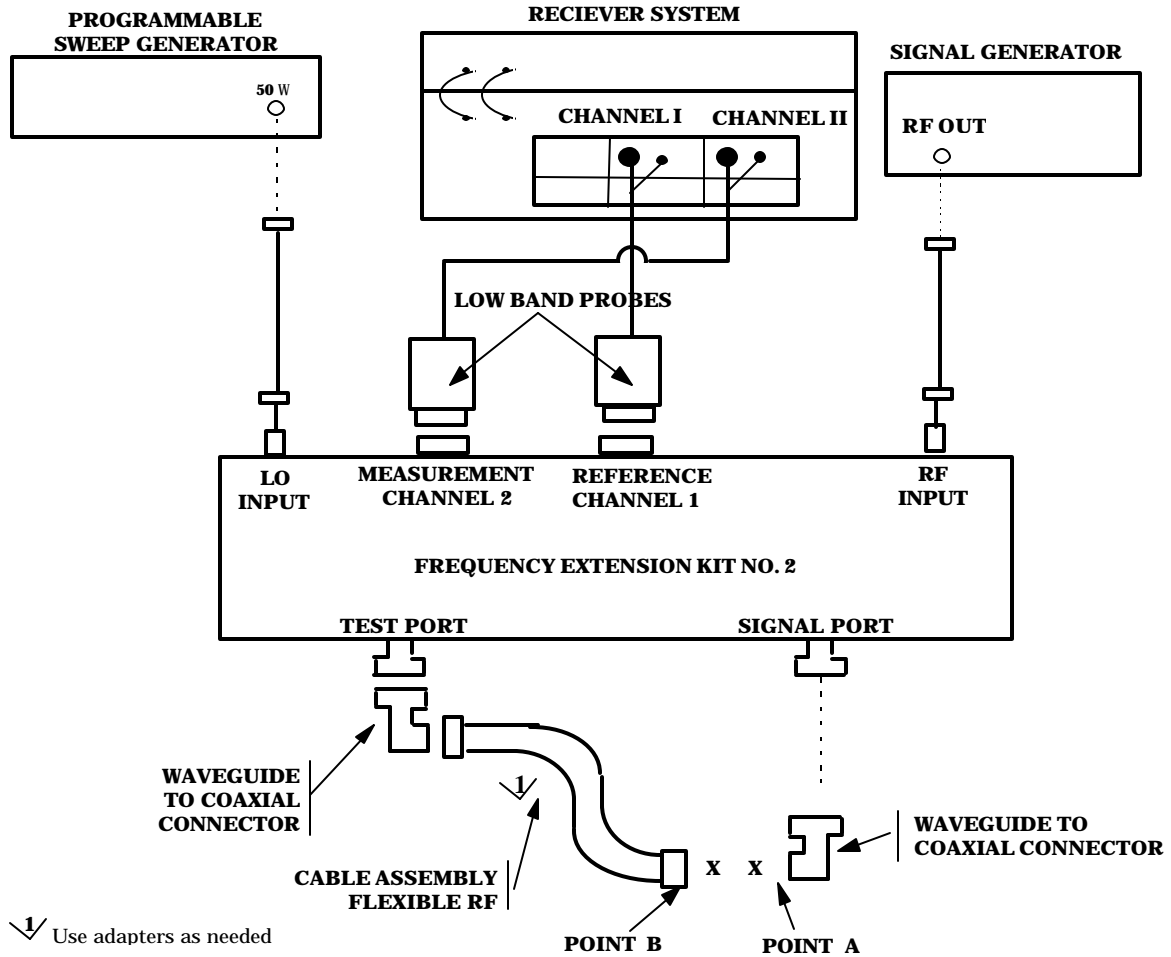

Figure 6. Power splitter measurement (26.5 to 40 GHz) - equipment setup

NOTE

Perform (36) through (48) below for TI with frequency range from 26.5 to 40 GHz.

- (36) Connect equipment as shown in figure 6.
- (37) Adjust programmable sweep generator frequency controls to 13.0 GHz output controls for 0 dBm.
- (38) Adjust signal generator frequency controls to 9000 MHz and and **RF LEVEL** output controls to +3 dBm.

NOTE

Use **15% SEARCH MODE** on receiver system.

(39) Press receiver system frequency to 1.000 GHz.

(40) Connect POINT A to POINT B (fig. 6) and establish a 0.00 dB reference on receiver system.

(41) Connect TI into figure 6 equipment setup as listed in (a) through (c) below:

- (a) **INPUT PORT 1** to POINT A.
- (b) **OUTPUT PORT 2** to POINT B.
- (c) **OUTPUT PORT 3** to 50Ω termination.

(42) Record receiver system indication in output port 2 column of table 7.

(43) Set programmable sweep generator and signal generator frequency controls to remaining settings listed in table 7. Measure and record insertion loss for output port 2 column in table 7.

Table 7. Insertion Loss - Output Port Tracking (26.5 to 40 GHz)

Actual test frequency (GHz)	Programmable sweep generator (LO) (GHz)	Signal generator (RF) (MHz)	Receiver system indication insertion loss		OUTPUT PORT TRACKING (dB)
			OUTPUT PORT 2 (dB)	OUTPUT PORT 3 (dB)	
27.0	13.0	9000			
28.0	13.5	9333			
29.0	14.0	9667			
30.0	14.5	10,000			
31.0	15.0	10,333			
32.0	15.5	10,667			
33.0	16.0	11,000			
34.0	16.5	11,333			
35.0	17.0	11,667			
36.0	17.5	12,000			
37.0	18.0	12,333			
38.0	18.5	12,667			
39.0	19.0	13,000			
40.0	19.5	13,333			

(44) Repeat (37) through (40) above.

(45) Connect TI into figure 6 equipment setup as listed in (a) through (c) below:

TB 9-5985-314-35

- (a) **INPUT PORT 1** to POINT A.
- (b) **OUTPUT PORT 3** to POINT B.
- (c) **OUTPUT PORT 2** to 50Ω termination.

(46) Record receiver system indication in output port 3 column of table 7.

(47) Adjust programmable sweep generator and signal generator frequency controls to remaining settings listed in table 7. Measure and record insertion loss for **OUTPUT PORT 3** in table 7.

(48) Algebraically calculate the difference between the values recorded in table 7 for **OUTPUT PORT 2** and **OUTPUT PORT 3**. Record difference in output port tracking column of table 7. **OUTPUT PORT TRACKING** will be within the limits specified in appendix D.

b. Adjustments. Prepare charts (if required) similar to tables 5, 6, and 7 for TI frequency range.

23. Final Procedure

- a. Deenergize and disconnect all equipment and reinstall protective cover on TI.
- b. Annotate and affix DA label/form in accordance with TB 750-25.

**APPENDIX A
DIRECTIONAL COUPLERS
TEST INSTRUMENT IDENTIFICATION**

Model/part number	Manufacturer	Frequency range (GHz)	Nominal coupling (dB) ¹²	Coupling variation (dB) ¹²	Frequency sensitivity (dB) ¹²	Directivity (dB) ¹
A414-10-FS1	PRD Electronic	26.5 to 40.0	10	±0.4 3	±0.5	40
CA-1 5N	MICROLAB/FXR	0.20 to 0.40	3(+0.2-0.0)	---	±0.5	25
C901 E	Wavecom	3.7 to 8.3	10	±0.3	N/A	37
DBH-675-10	Systron	7.05 to 10.0	10(±0.4)	±0.5	N/A	40
H752A	Hewlett-Packard	7.05 to 10.0	3	±0.5	N/A	40
H752C	Hewlett-Packard	7.05 to 10.0	10	±0.5	N/A	40
H752D	Hewlett-Packard	7.05 to 10.0	20	±0.5	N/A	40
K414-10-FS1	PRD Electronic	18.0 to 26.5	10	±0.4	±0.5	40
K752C	Hewlett-Packard	18.0 to 26.5	10	±0.5	N/A	40
L901 E	Wavecom	0.9 to 2.2	10	±0.5	N/A	45
MIS-10409-21	Military	Same as L901 E	---	---	---	---
MIS-10409-31	Military	Same as S901 E	---	---	---	---
M1537014-012	Military	Same as K414-10-FS1	---	---	---	---
P7520	Hewlett-Packard	12.4 to 18.0	10	±0.5	N/A	40
P752D	Hewlett-Packard	12.4 to 18.0	20	±0.5	N/A	40
P901	Wavecom	0.5 to 1.0	10	N/A	N/A	48
R752C	Hewlett-Packard	26.5 to 40.0	10	±0.6	N/A	40
S901 E	Wavecom	1.7 to 4.2	10	N/A	N/A	42
U901	Wavecom	0.1 to 0.5	10	±0.5	N/A	48
X752A	Hewlett-Packard	8.2 to 12.4	3(±0.4)	±0.5	N/A	40
X752C	Hewlett-Packard	8.2 to 12.4	10(±0.4)	±0.5	N/A	40
X752D	Hewlett-Packard	8.2 to 12.4	20 (±0.4)	±0.5	N/A	40
X901	Wavecom	7.0 to 12.4	10	±0.3	N/A	33
1070-10	Narda	8.2 to 12.4	10 ±0.2	±0.4	±0.5	40
11691 D OPT001	Hewlett-Packard	2.0 to 18.0	22	±1.0	N/A	30 (2.0 to 8 GHz) 26(8 to 18 GHz) 24 (w/N-type connector)
11692D	Hewlett-Packard	2.0 to 18.0	22	±1.0	N/A	Same as 11691D and 24 test port (w/N-type connector)
3000-10	Narda	0.225 to 0.46	10±(0.1) ⁴	±1.0	N/A	30
3000-20	Narda	0.225 to 0.46	20 (±0.1) ⁴⁵	±1.0	N/A	30
3000-30	Narda	0.225 to 0.46	30 (±0.1) ⁴⁵	±1.0	N/A	30
3001-10	Narda	0.46 to 0.95	10 (±0.1) ⁴	±1.0	N/A	30
3001-20	Narda	0.46 to 0.95	20 (±0.1) ⁴⁵	±1.0	N/A	30
3002-10	Narda	0.95 to 2.0	10 (±0.1) ⁴	±1.0	N/A	30
3002-20	Narda	0.95 to 2.0	20 (±0.1) ⁴⁵	±1.0	N/A	30
3002-30	Narda	0.95 to 2.0	30 (±0.1) ⁴⁵	±1.0	N/A	30

See footnotes at end of table.

**APPENDIX A
DIRECTIONAL COUPLERS
TEST INSTRUMENT IDENTIFICATION - Continued**

Model/part number	Manufacturer	Frequency range (GHz)	Nominal coupling (dB) ¹²	Coupling variation (dB) ¹²	Frequency sensitivity (dB) ¹²	Directivity (dB) ¹
3003-10	Narda	2.0 to 4.0	10 (± 0.1) ⁴	± 1.0	N/A	25
3003-20	Narda	2.0 to 4.0	20 (± 0.1) ⁴⁵	± 1.0	N/A	27
3004-10	Narda	4.0 to 10.0	10 (± 0.4) ⁴	N/A	± 1.2	20 (4 to 8 GHz) 17 (8 to 10GHz)
3004-20	Narda	4.0 to 10.0	20 (± 0.4) ⁴⁵	N/A	± 1.2	20 (4 to 8 GHz) 17 (8 to 10GHz)
3020A	Narda	0.05 to 1.0 0.25 to 1.0	20 to 33 (0.05 to 0.25 GHz) (± 0.1) ⁵ 20 (0.25 to 1.0 GHz)	N/A ± 1.0 (0.25 to 1.0 GHz)	N/A	35
3022	Narda	1 to 4	20 (± 0.1) ⁴⁵	± 1.0	N/A	1 to 3 GHz 30 3 to 4 GHz 27
3024	Narda	4.0 to 8.0	20 (± 0.1) ⁴⁵	± 1.0	N/A	25
3039-20	Narda	0.125 to 0.25	20 (± 0.1) ⁴⁵	± 0.5	± 0.2	20
3043B-10	Narda	1.7 to 4.2	10 (± 0.1) ⁴	± 0.5	± 0.2	20
3043B-20	Narda	1.7 to 4.2	20 (± 0.1) ⁴⁵	± 0.5	± 0.2	20
3044B-20	Narda	3.7 to 8.3	20 (± 0.1) ⁴⁵	± 0.5	± 0.2	17
3045C-10	Narda	7.0 to 12.4	10 (± 0.1) ⁴	± 0.5	± 0.2	15
3045C-20	Narda	7.0 to 12.4	20 (± 0.1) ⁴⁵	± 0.5	± 0.2	15
3045C-30	Narda	7.0 to 12.4	30 (± 0.1) ⁴⁵	± 0.5	± 0.2	15
3060-20	Narda	10 to 200MHz ⁶	20 (± 0.2) ⁴⁵	± 0.8	± 0.5	20
3092	Narda	0.95 to 2.2	10 (± 0.1) ⁴	N/A	± 1.2	45
3093	Narda	1.7 to 4.2	10 (± 0.1) ⁴	N/A	± 1.2	42
3094	Narda	3.7 to 8.3	10 (± 0.1) ⁴	N/A	± 1.2	37
30953	Narda	7.0 to 12.4	10 (± 0.1) ⁴	N/A	± 1.2	33
4002B-10	Narda	0.125 to 0.25	10 (± 1.25)	N/A	± 0.75	25
40852	PRD Electronic	8.2 to 12.4	10	3	± 0.6	40
40854	PRD Electronic	8.2 to 12.4	20	± 0.4	± 0.5	40
413S1	PRD Electronic	12.4 to 18.0	10	± 0.4	± 0.5	40
430-10S1	PRD Electronic	0.2 to 1.0	10	± 1.0	± 0.2	20
431-10S1	PRD Electronic	0.95 to 2.0	10	± 1.0	± 0.2	15
432-10S1	PRD Electronic	2.0 to 4.0	10	± 1.0	± 0.2	15
432-20S2	PRD Electronic	2.0 to 4.0	20	± 0.5	± 1.0	25
433-10S1	PRD Electronic	4.0 to 8.0	10	± 1.0	± 0.2	15
433-10S2	PRD Electronic	4.0 to 8.0	10	± 0.5	± 1.0	20
434-10S1	PRD Electronic	7.0 to 11.0	10	± 1.0	± 0.2	15
60543	Waveline	8.2 to 12.4	10	± 0.4	± 0.5	40
674-40	Waveline	8.2 to 12.4	40(± 0.3)	± 0.5	N/A	40

See footnotes at end of table.

**APPENDIX A
DIRECTIONAL COUPLERS
TEST INSTRUMENT IDENTIFICATION - Continued**

Model/part number	Manufacturer	Frequency range (GHz)	Nominal coupling (dB) ¹²	Coupling variation (dB) ¹²	Frequency sensitivity (dB) ¹²	Directivity (dB) ¹
774-30	Waveline	12.4 to 18.0	30(±0.3)	±0.5	N/A	40
774-40	Waveline	12.4 to 18.0	40(±0.3)	±0.5	N/A	40
776D	Hewlett-Packard	0.94 to 1.9	20	±1.0	N/A	40
778D	Hewlett-Packard	0.1 to 2.0	20 ⁷	±1.5 ⁸	±1.0	36 (0.1 to 1.0 GHz) 32 (1 to 2 GHz) 30 (0.1 to 2 GHz, B port)
7913359-2-2	Military	8.2 to 12.4	10	±0.4	±0.5	40
797D	Hewlett-Packard	1.9 to 4.1	20(±0.5)	±0.2	N/A	26
7923152	Military	Same as K414-40-FS1	---	---	---	---
7923153	Military	Same as A414-10-FS1	---	---	---	---
874-40	Waveline	18.0 to 26.5	40 (±0.3)	±0.5	N/A	40

¹See paragraph 7 for definitions.

²Nominal coupling tolerances are the linear combination of coupling variation and frequency sensitivity nominal coupling tolerance (±(coupling variation) + (±(frequency sensitivity). Example: Hewlett-Packard, Model 776D - 20 (nominal coupling) = 20 ±1 dB over TI's frequency range.

³Provide correction chart of receiver system actual indications.

⁴Absolute calibration accuracy for manufacturer selected frequencies stamped on data plate of TI.

⁵Per 10 dB step.

⁶Use test frequencies of: 10, 30, 60, 100, 150, and 200 MHz.

⁷Decreasing frequency from 0.45 to 0.1 GHz has an increasing slope of 0.006 dB/MHz. Example: nominal coupling (dB) at 0.1 GHz is 22.1.

⁸Above 0.45 GHz.

**APPENDIX B
VSWR BRIDGES
TEST INSTRUMENT IDENTIFICATION**

Model/part number	Manufacturer	Frequency range (GHz)	Directivity (dB)
60NF50	Wiltron	5 MHz to 2 GHz ¹	40
87A50-1	Wiltron	2 to 18 GHz	38

¹Not calibrated below 10 MHz.

TB 9-5985-314-35

**APPENDIX C
3 PORT CIRCULATOR
TEST INSTRUMENT IDENTIFICATION**

Model/part number	Manufacturer	Frequency range (GHz)	Isolation (dB min)	Insertion loss (dB max)
DF 2407	Ditcom Microwave	Same as M3B-1030		
M3B-1030	Omnispectra	0.960 to 1.100	20	0.5
7916840	Same as M3B-1030			

**C-1
CHANGE 1**

**APPENDIX D
POWER SPLITTERS AND POWER DIVIDERS
TEST INSTRUMENT IDENTIFICATION**

Model/part number	Manufacturer	Frequency range (GHz) ¹	Insertion loss (dB min)	OUTPUT PORT tracking (dB) ²
K241 () ³	Wiltron	Dc to 40	7.0	±0.3
		Dc to 6	7.5	±0.3
		6 to 18	8.0	±0.6
		18 to 26.5	8.5	±0.6
		26.5 to 40		
PS018	Weinschel	Dc to 4	6 ⁶	≤0.15
		4 to 8		≤0.20
		8 to 18		≤0.25
1506A	Weinschel	Dc to 18	6 -0.2 +1.2 (max to 10 GHz) +1/5 (max to 18 GHz)	±0.2
		Dc to 4		±0.4
		4 to 10		±0.5
		10 to 18		
1870A ⁴	Weinschel	Dc to 18	6 -0.2 +1.5	±0.15
		Dc to 2		±0.2
		2 to 8		±0.25
		8 to 18		
11667A	Hewlett-Packard	Dc to 4	6 ⁶	≤0.15
		4 to 8		≤0.20
		8 to 18		≤0.25
11667B ⁵	Hewlett-Packard	Dc to 26.5	6 ⁶	±0.25
		Dc to 18		±0.40
		18 to 26.5		

¹Not checked below 10 MHz.

²Between output ports.

³Attach test report for the frequencies requested or required by customer.

⁴Attach test report for the frequencies requested or required by customer.

⁵Attach test report for the frequencies requested or required by customer.

⁶Value determined in calibration process.

TB 9-5985-314-35

By Order of the Secretary of the Army:

DENNIS J. REIMER
General, United States Army
Chief of Staff

Official:



Handwritten signature of Joel B. Hudson in black ink.

JOEL B. HUDSON

*Administrative Assistant to the
Secretary of the Army*

03091

Distribution:

To be distributed in accordance with DA Form 12-34-E, Block No. 2085, requirements for calibration procedure TB 9-5985-314-35.

US GOVERNMENT PRINTING OFFICE: 1997 - 532-280/40147

PIN NO: 048800-001